

PLEASE KEEP ME WITH YOUR PROOF OF PURCHASE FOR FUTURE REFERENCE.



## ASSEMBLY INSTRUCTIONS

### MEDITERRANEAN PARASOL

(13102164 – DOVE)





(13102154 – GREY)

#### ATTENTION:

1. Please read these instructions carefully before assembly
2. Please allow 15 minutes for assembly.
3. Although assembly only requires 1 person it is advised that a second person be present to help place into position when fully assembled.

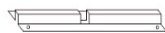
#### Care for the canopy:



- Simply clean the umbrella canopy with a soft brush and mild detergent.
- Do not machine wash or machine dry.
- Do not iron.

Component's				Component's					
Parts List	Parts Picture	Description	Q'ty	Component no.	Parts List	Parts Picture	Description	Q'ty	Component no.
A		Cross Base A	1	13102164A 13102154A	E		Washers ( $\phi$ 16/ $\phi$ 8.2*1.2)	4	1061162
B		Cross Base B	1	13102164B 13102154B	F		Wrench (M8)	1	2100046

For replacement or lost spare parts please go to <http://faq.hartmanuk.co.uk/spares/>

Should you have any queries about your furniture your first point of contact should be the retailer from whom you purchased your product.

PLEASE KEEP ME WITH YOUR PROOF OF PURCHASE FOR FUTURE REFERENCE.

C		Support Pole	1	13102164C 13102154C	G		Parasol	1	13102164D 13102154D
---	---	--------------	---	------------------------	---	--	---------	---	------------------------

• Air-dry the canopy thoroughly in an open position before storing for extended periods of time.

**IMPORTANT!** Always close/put down the parasol when not in use. Do not use or assemble the parasol in wind, rain, thunderstorms or if it's snowing. In these weather conditions, we recommend to fold down or disassemble the parasol. Disassemble by following the setup steps in this manual.

**IMPORTANT!** The parasol must be secured in place using a parasol base. Make sure the ground is level and firm.

**IMPORTANT!** If the crank gets too hard to turn, check if the rope has come off the pulley. If you continue to turn the crank, the rope or crank handle could break.

**IMPORTANT!** Placing the parasol over or near a swimming pool can cause premature fading of the canopy.

**WARNING:** Do not assemble the parasol on sandy, muddy or loose soil.



Keep children and pets away while setting up the parasol.

Children must be supervised around the parasol.

This parasol is for outdoor use only.

Do not light any fires under or near the parasol!

This parasol is primarily intended to be used as a sunshade and not as wind protection.

D		Bolts ( $\phi$ 8*20)	4	2100045	H		Cover	1	13102164E 13102154E
---	--	-------------------------	---	---------	---	---	-------	---	------------------------

For more information regarding maintenance of your furniture please visit [http://www.hartmanuk.co.uk/after\\_care\\_videos.html](http://www.hartmanuk.co.uk/after_care_videos.html)

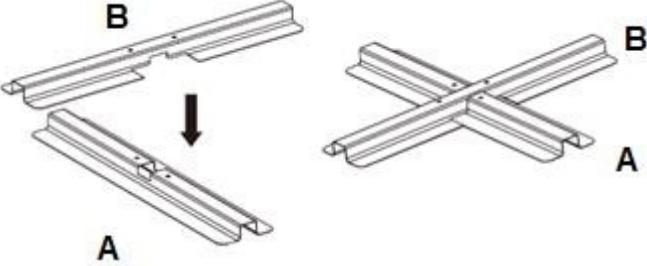
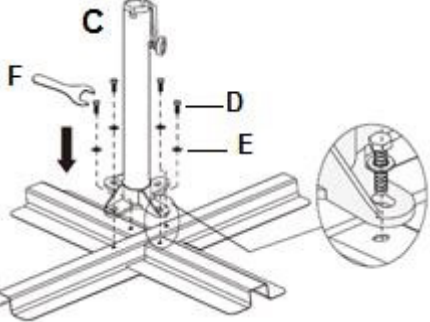
<p><b>Step 1</b> Place Cross Base (A) on a soft surface, line up not and place Cross Base (B) over Cross Base (A).</p>	<p><b>Step 2</b> Attach Support Pole(C) to Cross Base by using Bolts(D) and Washers(E), hand tighten only. Adjust the Support Pole (C) to be sure it is positioned correctly on the Cross Base and finally tighten all Bolts with Wrench(F). <b>Be careful not to over tighten.</b></p>
	
<p><b>Step 3</b> Insert the Parasol (G) into Support Pole (C).</p>	<p><b>Step 4</b> Unlock the clip to raise the canopy arm</p>

For replacement or lost spare parts please go to <http://faq.hartmanuk.co.uk/spares/>

**Should you have any queries about your furniture your first point of contact should be the retailer from whom you purchased your product.**

PLEASE KEEP ME WITH YOUR PROOF OF PURCHASE FOR FUTURE REFERENCE.

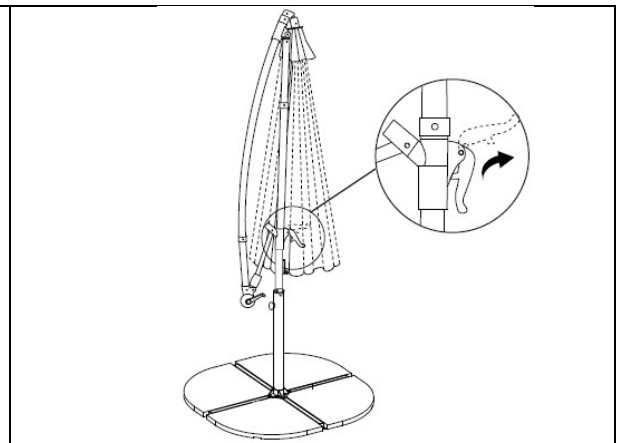
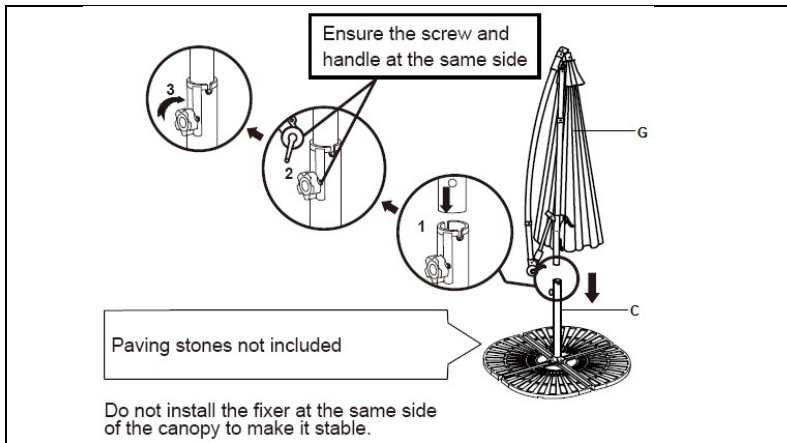

**Step 5**

Ensure the clip is locked into place to secure the canopy arm in place

**Step 6**

Turn the crank handle in clockwise direction to open the parasol canopy.

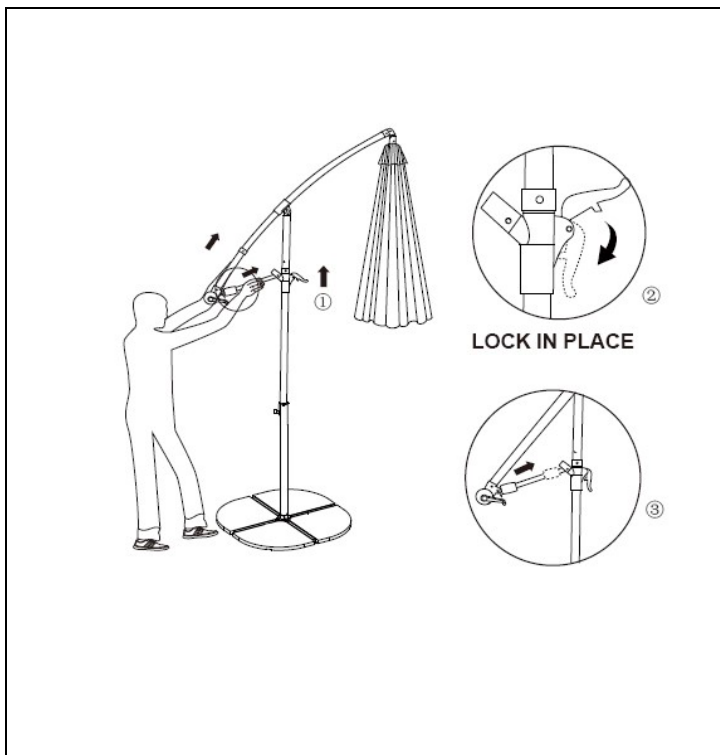

**Step 7**

Turn the crank handle counter clockwise to close the parasol.

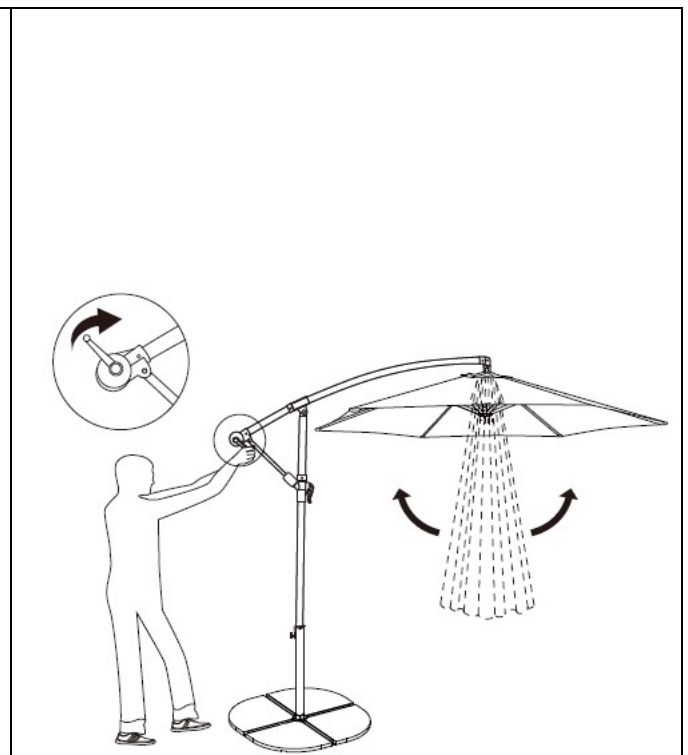

**Step 8**

DO NOT JUST FOLD DOWN SUDDENLY, OR THE PLASTIC PART (L) WILL BE EASILY BROKEN.

For replacement or lost spare parts please go to <http://faq.hartmanuk.co.uk/spares/>

Should you have any queries about your furniture your first point of contact should be the retailer from whom

you purchased your product.

PLEASE KEEP ME WITH YOUR PROOF OF PURCHASE FOR FUTURE REFERENCE.

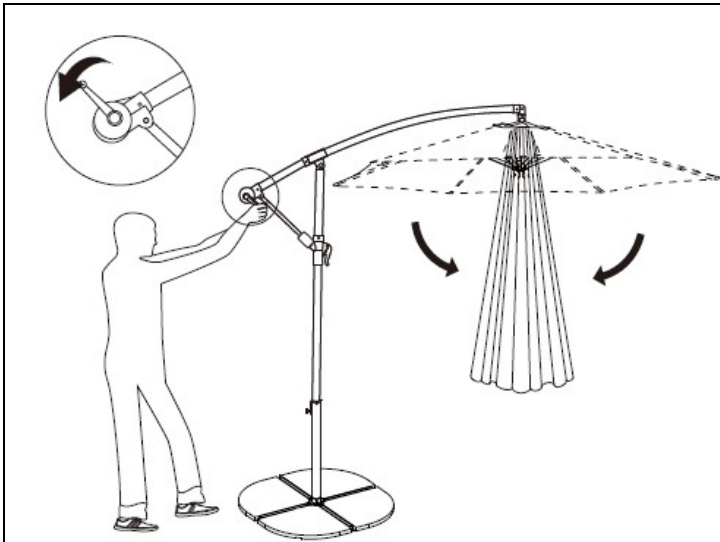

**Step 9**

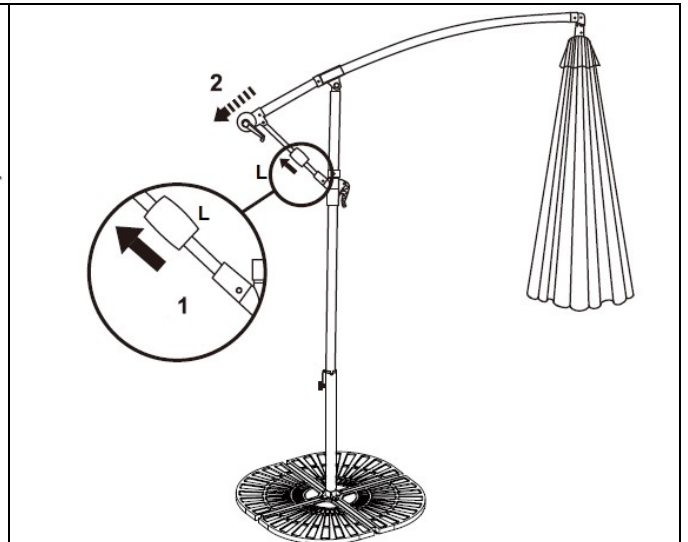

**Step 10**

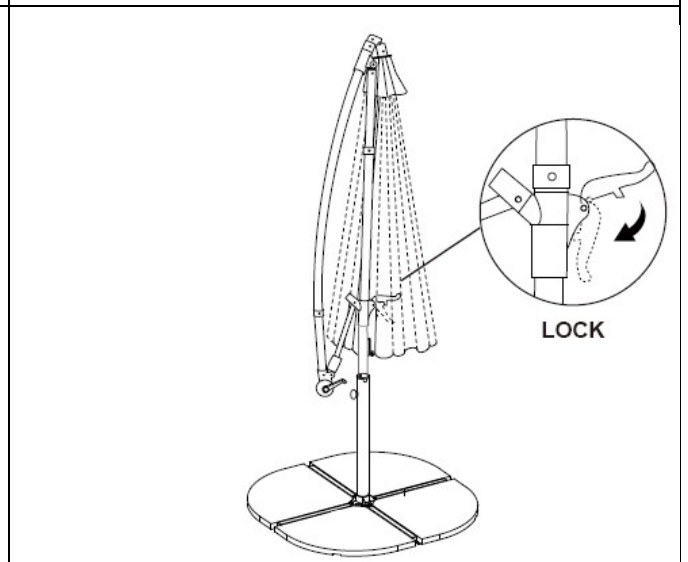
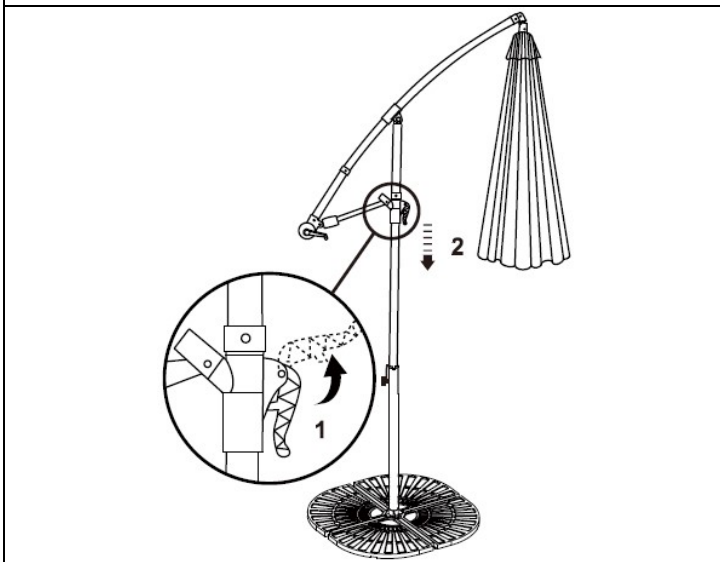

**Step 10**

Use Cover (H) when your parasol is not in use.

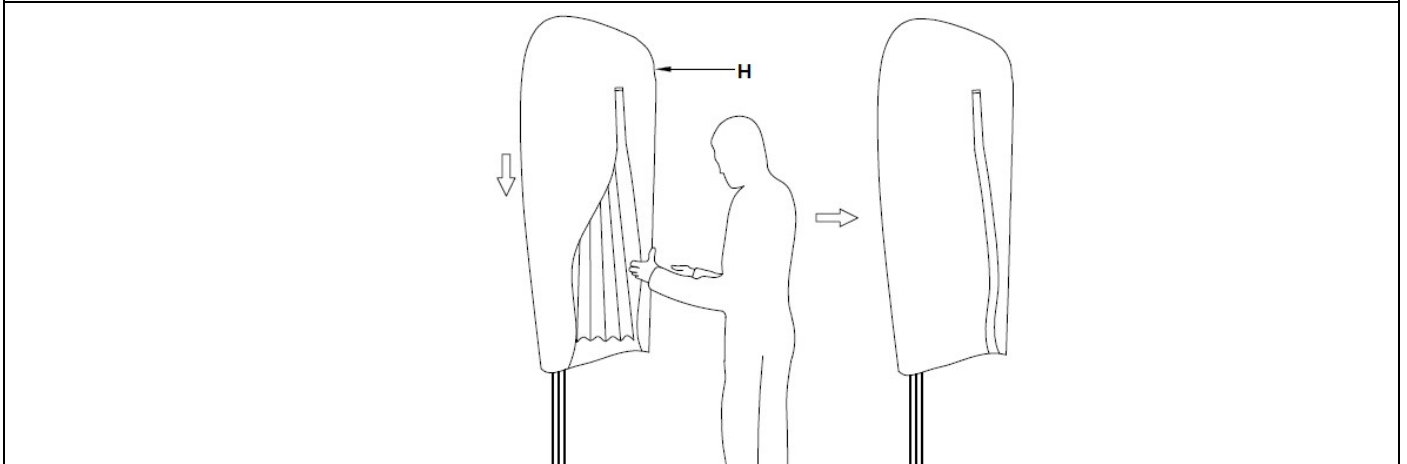

For replacement or lost spare parts please go to <http://faq.hartmanuk.co.uk/spares/>

Should you have any queries about your furniture your first point of contact should be the retailer from whom

you purchased your product.