

PLEASE KEEP ME WITH YOUR PROOF OF PURCHASE FOR FUTURE REFERENCE



ASSEMBLY INSTRUCTIONS

Westbury 150x80cm Rectangular Table

(68174147 / 68182146)

ATTENTION:









1. Please read these instructions carefully before assembly
2. Aluminium is a soft metal and over tightening may strip thread or break the part
3. **DO NOT** use power tools
4. Please allow 30 minutes for assembly
5. Although assembly only requires 1 person it is advised that a second person be present to help turn the table over and into position when fully assembled

ASSEMBLY STEPS:

1. **LOOSELY** attach legs (B) to table top (A) with bolts (E) and big flat washers (F) using Allen key (H) **DO NOT TIGHTEN THE BOLTS AT THIS STAGE**
2. **LOOSELY** attach connecting bar (C) to assembled legs with bolts (E) and big flat washers (F) using Allen key (H) **DO NOT TIGHTEN THE BOLTS AT THIS STAGE**
3. Tighten all bolts using Allen key one by one being careful not to over tighten any as this will cause the thread to become damaged
4. Place Nut Caps (G) on all visible bolts (E)
5. Turn table top over and place in desired position, be careful to put glass (D) on table top

For more information regarding maintenance of your furniture please visit

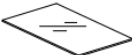
<https://www.hartmanuk.com/home>

Component's				Fixings					
Parts List	Parts Picture	Description	Q'ty	Part no	Parts list	Parts Picture	Description	Q'ty	Part no.
A		Table Top	1	68174147A 68182146A	E		M6*25 bolt	8	1231162
B		Legs	2	68174147B 68182146B	F		Flat washer	8	1061162
C		Connecting bar	1	68174147C 68182146C	G		PVC cap	8	2100036 2100037
D		Glass		68174147D 68182146D	H		Allen key	1	2002191

For replacement or lost spare parts please go to <http://spares.hartmanuk.co.uk/purchase>

Should you have any queries about your furniture your first point of contact should be the retailer from whom you purchased your product

PLEASE KEEP ME WITH YOUR PROOF OF PURCHASE FOR FUTURE REFERENCE



ASSEMBLY INSTRUCTIONS

Westbury 150x80cm Rectangular Table

(68174147 / 68182146)

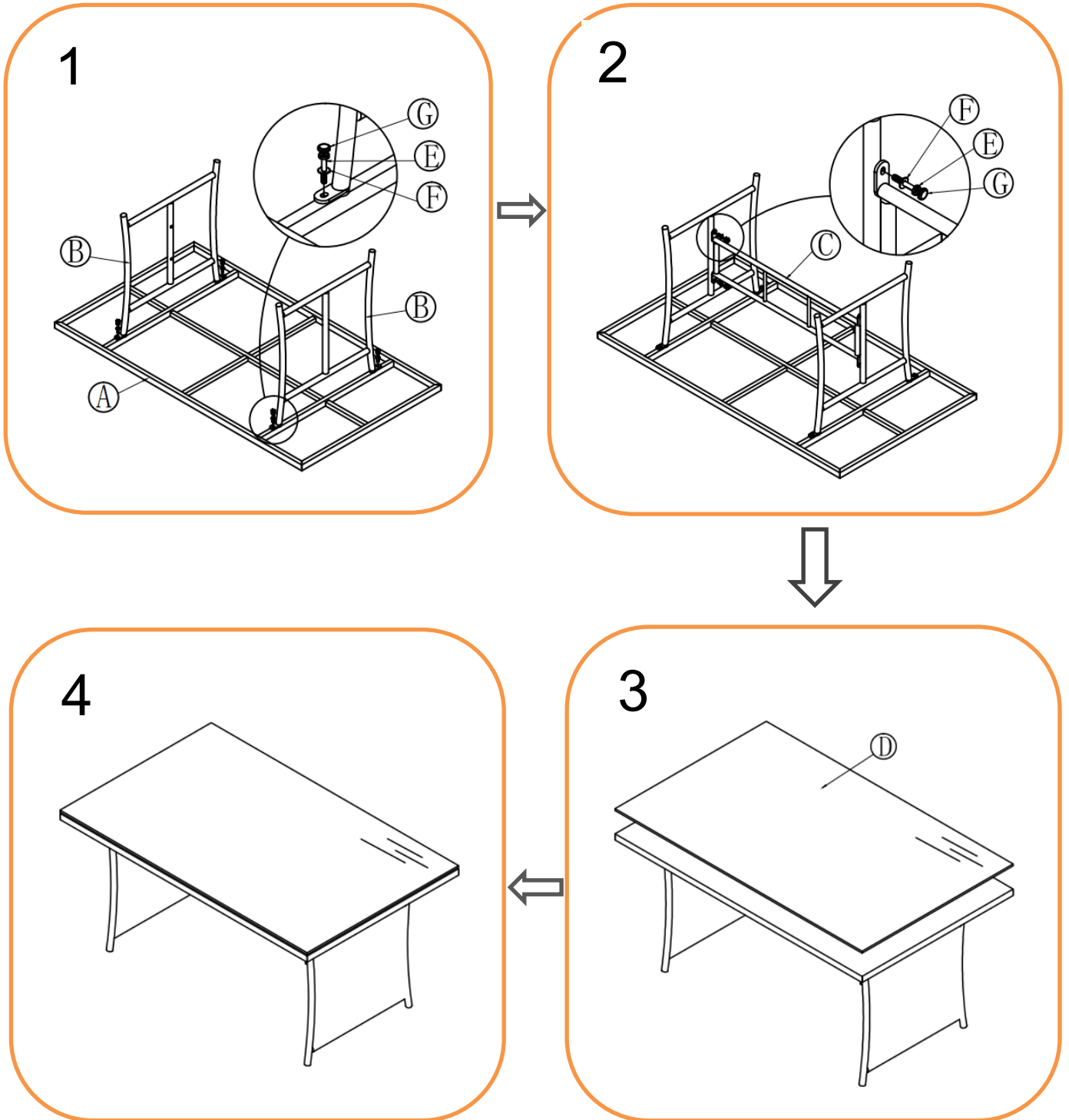

For replacement or lost spare parts please go to <http://spares.hartmanuk.co.uk/purchase>

Should you have any queries about your furniture your first point of contact should be the retailer from whom you purchased your product

PLEASE KEEP ME WITH YOUR PROOF OF PURCHASE FOR FUTURE REFERENCE



ASSEMBLY INSTRUCTIONS

Westbury Rectangular Casual Dining Corner (3 Seater + 3 Seater)

(68175147 / 68183146)

ATTENTION:







1. Please read these instructions carefully before assembly
2. Aluminium is soft metal and over tightening may strip thread or break the part
3. **DO NOT** use power tools
4. Please allow 30 minutes for assembly
5. Although assembly only requires 1 person it is advised that a second person be present to help turn the sofa over and into position when fully assembled

ASSEMBLY STEPS:

1. Position part (A) and part (B) ready for assembly
2. **LOOSELY** attach backrest (A) to seating section (B) using 6 bolts (F) and 6 flat washers (C) with spanner (G) **DO NOT TIGHTEN BOLTS AT THIS STAGE.**
3. **LOOSELY** attach front and rear leg to seating section (B) using 2 bolts (D) and 2 flat washers (C) with spanner (G) **DO NOT TIGHTEN BOLTS AT THIS STAGE.**
4. **BOLTS AT THIS STAGE.**
5. Tighten all bolts using the spanner (G) cover all bolts using nut cap (E)
6. Turn it over and place in desired position

For more information regarding maintenance of your furniture please visit

<https://www.hartmanuk.com/home>

Component's					Fixings				
Parts List	Parts Picture	Description	Q'ty	Part no	Parts list	Parts Picture	Description	Q'ty	Part no.
A		Backrest with LH arm	1	68175147A 68183146A	C		Big Flat Washers	8	1061162
B		Seating Section	1	68175147B 68183146B	D		M6*50 bolts	2	2002162
					E		PVC cap	8	2100036 2100037
					F		M6*45 bolts	6	1131162
					G		Spanner	1	2100041

For replacement or lost spare parts please go to <http://spares.hartmanuk.co.uk/purchase>

Should you have any queries about your furniture your first point of contact should be the retailer from whom you purchased your product



ASSEMBLY INSTRUCTIONS

Westbury Rectangular Casual Dining Corner (3 Seater + 3 Seater)

(68175147 / 68183146)

1

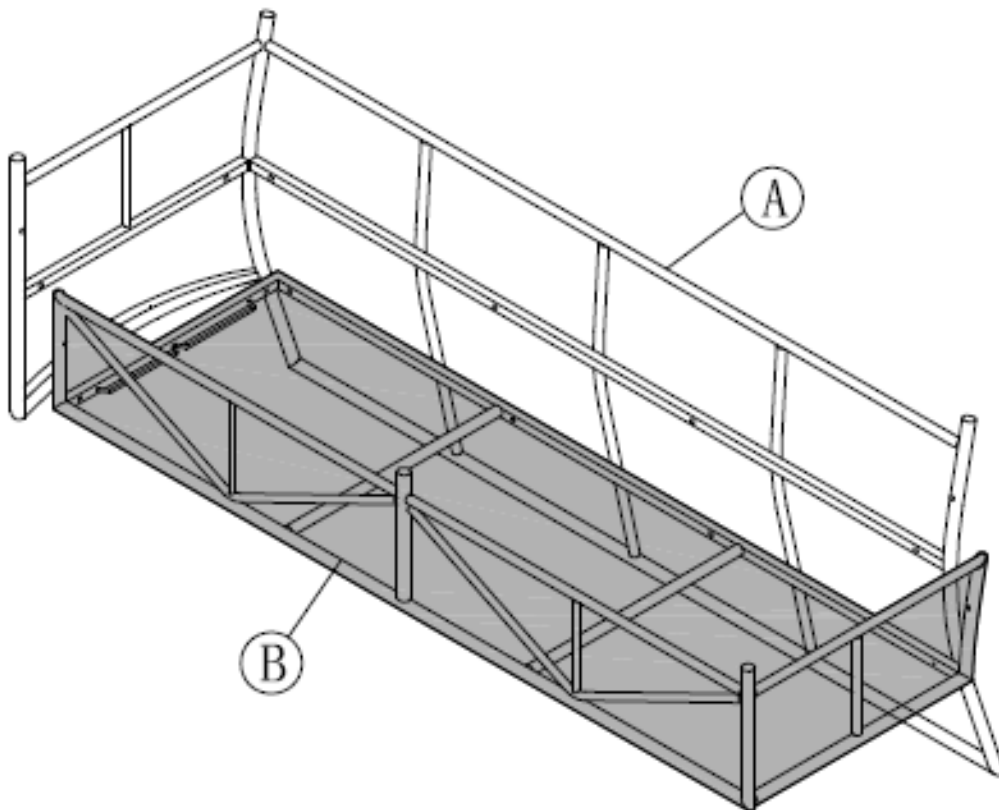

For replacement or lost spare parts please go to <http://spares.hartmanuk.co.uk/purchase>

Should you have any queries about your furniture your first point of contact should be the retailer from whom you purchased your product

PLEASE KEEP ME WITH YOUR PROOF OF PURCHASE FOR FUTURE REFERENCE

2

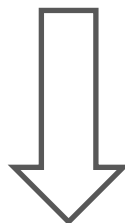
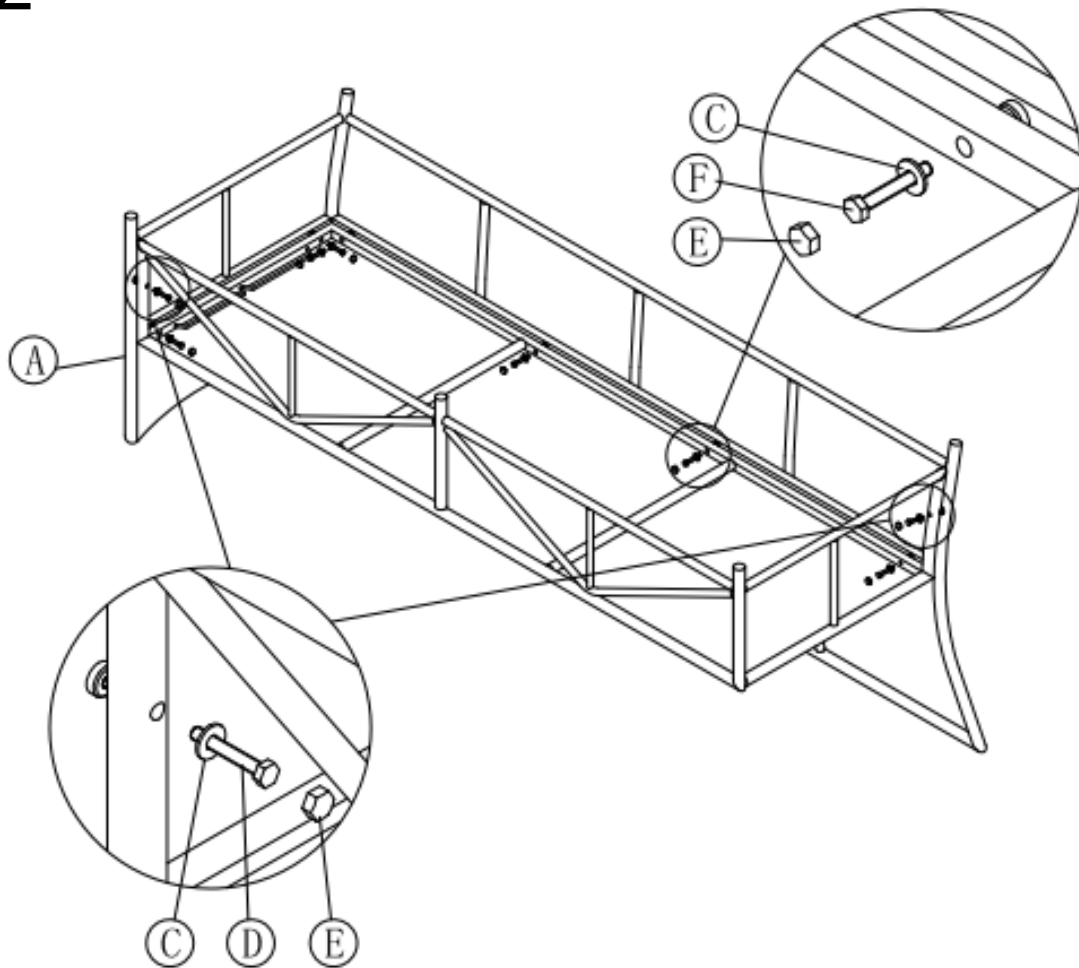

For replacement or lost spare parts please go to <http://spares.hartmanuk.co.uk/purchase>

Should you have any queries about your furniture your first point of contact should be the retailer from whom you purchased your product

PLEASE KEEP ME WITH YOUR PROOF OF PURCHASE FOR FUTURE REFERENCE

3

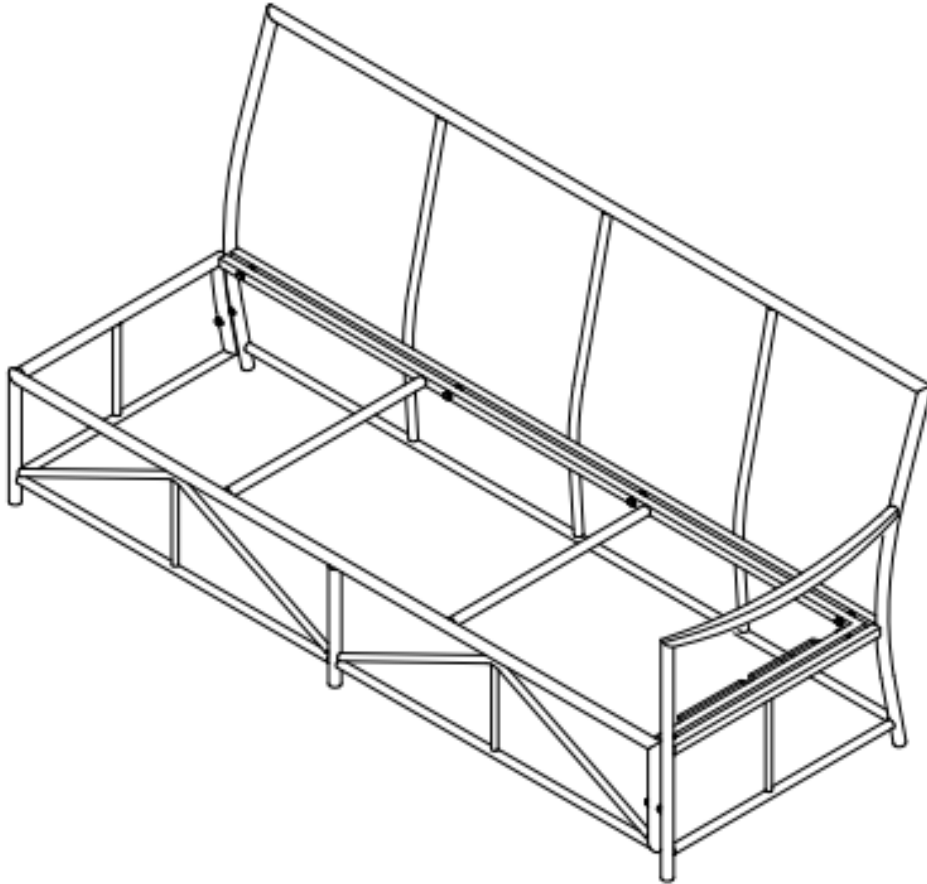

For replacement or lost spare parts please go to <http://spares.hartmanuk.co.uk/purchase>

Should you have any queries about your furniture your first point of contact should be the retailer from whom you purchased your product

PLEASE KEEP ME WITH YOUR PROOF OF PURCHASE FOR FUTURE REFERENCE

ATTENTION:



1. Please read these instructions carefully before assembly
2. Aluminium is soft metal and over tightening may strip thread or break the part
3. **DO NOT** use power tools
4. Please allow 30 minutes for assembly
5. Although assembly only requires 1 person it is advised that a second person be present to help turn the sofa over and into position when fully assembled

ASSEMBLY STEPS:

1. Position part (A1) and part (B1) ready for assembly
2. With 2 brackets (C1) position over the section that adjoin parts (A1) and (B1).
3. Turn sofas over and place in desired position.
4. Put all cushions on the sofa

For more information regarding maintenance of your furniture please visit

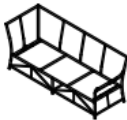
<https://www.hartmanuk.com/home>

Component's				Fixings					
Parts List	Parts Picture	Description	Q'ty	Part no	Parts list	Parts Picture	Description	Q'ty	Part no.
A1		RH Sofa	1	68175147A1 68186146A1					
B1		LH Sofa	1	68175147B1 68186146B1					
C1		Bracket	2	2002188					

For replacement or lost spare parts please go to <http://spares.hartmanuk.co.uk/purchase>

Should you have any queries about your furniture your first point of contact should be the retailer from whom you purchased your product

PLEASE KEEP ME WITH YOUR PROOF OF PURCHASE FOR FUTURE REFERENCE

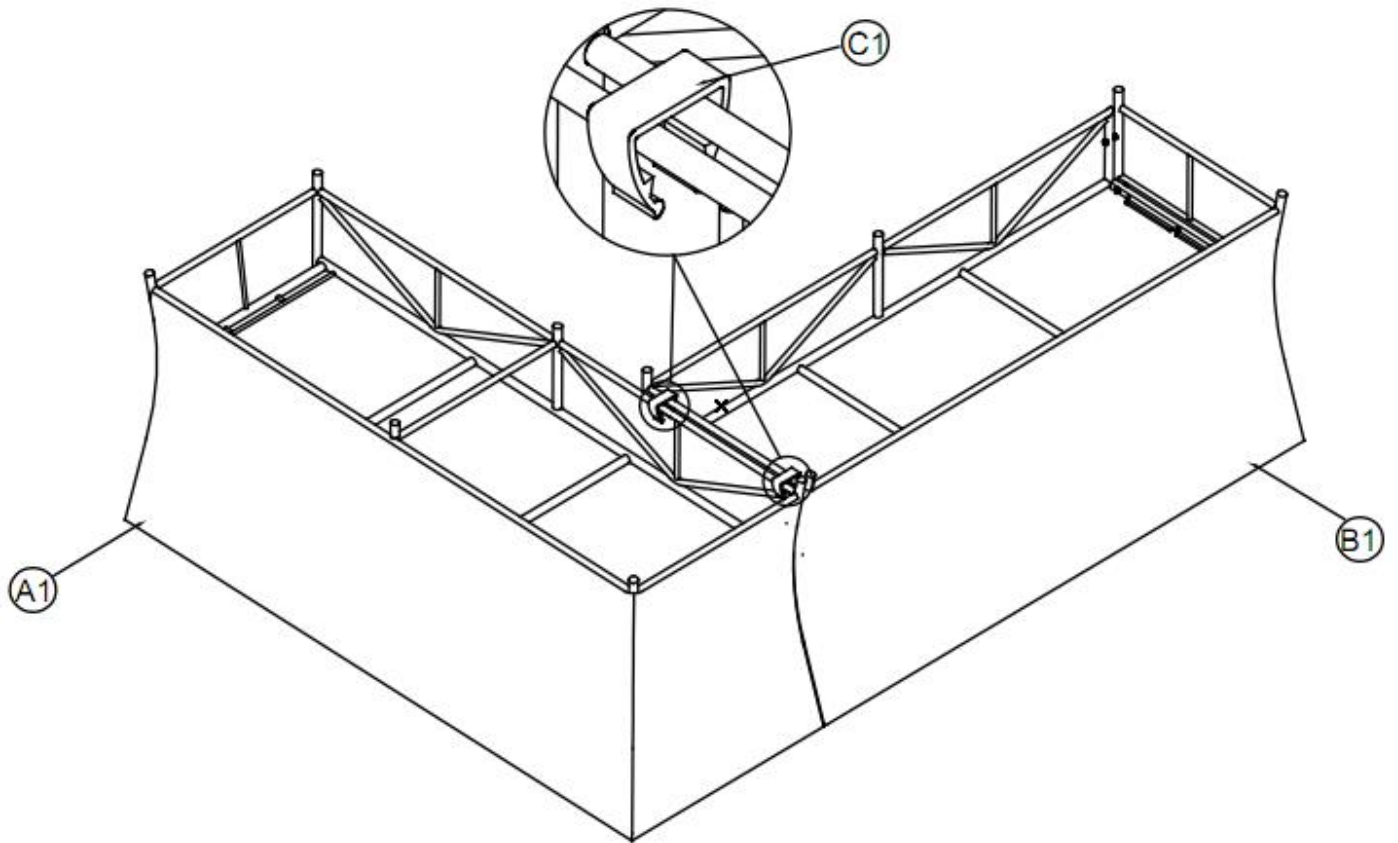

For replacement or lost spare parts please go to <http://spares.hartmanuk.co.uk/purchase>
Should you have any queries about your furniture your first point of contact should be the retailer from whom you purchased your product