

PLEASE KEEP ME WITH YOUR PROOF OF PURCHASE FOR FUTURE REFERENCE



ASSEMBLY INSTRUCTIONS

Heritage Grand Rectangular Gas Fire Pit Table

(68171145 / 68172145 / 68191146 / 68192146)

ATTENTION:







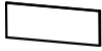

1. Please read these instructions carefully before assembly
2. Aluminium is a soft metal and over tightening may strip the thread or break the part
3. **DO NOT** use power tools
4. Please allow 30 minutes for assembly
5. Although assembly only requires 1 person it is advised that a 2nd person be present to help turn the table over and into position when fully assembled

ASSEMBLY STEPS:

1. Turn table top over and put onto a soft clean surface, be careful of the glass fixed on table top and there is no need to take out of the glass
2. **LOOSELY** attach base section (B) to table top (A) with bolts (E) and big flat washers (F) using Allen key (J) **DO NOT TIGHTEN THE BOLTS AT THIS STAGE**
3. **LOOSELY** attach the igniter switch with bolts (E) and big flat washers (F) using Allen key(J)
4. Tighten all bolts one by one using Allen key, being careful not to over tighten any as this will cause the thread to become damaged
5. Turn table top over and place in desired position, be careful of the glass fixed on table top while turning over the table
6. Push the door on the base open along the track, connect the gas pipe then put the gas tank on the track and push to close the door
7. Pour the bag of glass beads (D) into fire pit, these do not cover the fire burner completely, as excessive heat may cause them to crack
8. Put the centre glass (C) on top of the fire pit
9. Fire guard: fix 4pc glass (G) and (H) onto the glass clips (I). Note: When installing the glass clips, the direction of the clip on the same piece of glass must be in reverse.
10. Put the assembled fire guard on the correct position on table top, the table is assembled completely.

For more information regarding maintenance of your furniture please visit

<https://www.hartmanuk.com/home>

Component's					Fixings				
Parts List	Parts Picture	Description	Q'ty	Part no	Parts list	Parts Picture	Description	Q'ty	Part no.
A		Table Top with Glass	1	68171145A 68191146A	G		Fire Guard Glass	2	2200012
B		Base	1	68172145B 68192146B	H		Fire Guard Glass	2	2200013
C		Centre glass	1	67181145C 68191146C	I		Glass clip	8	2100042
D		Glass beads	1	68171145D	J		Allen key	1	2002191
E		M6*20 bolts	8	1017162					
F		Flat washer	8	1061162					

For replacement or lost spare parts please go to <http://spares.hartmanuk.co.uk/purchase>

Should you have any queries about your furniture your first point of contact should be the retailer from whom you purchased your product

PLEASE KEEP ME WITH YOUR PROOF OF PURCHASE FOR FUTURE REFERENCE



ASSEMBLY INSTRUCTIONS

Heritage Grand Rectangular Gas Fire Pit Table

(68171145 / 68172145 / 68191146 / 68192146)

1

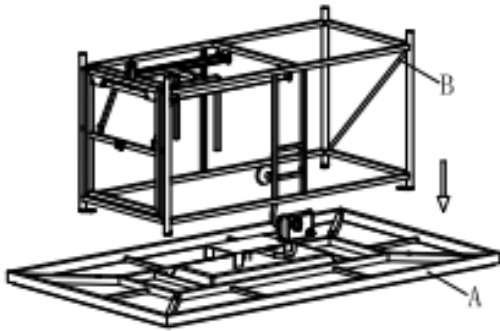

2

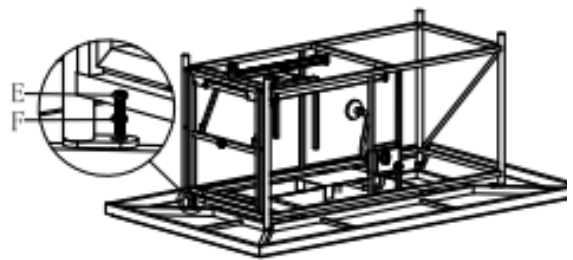

3

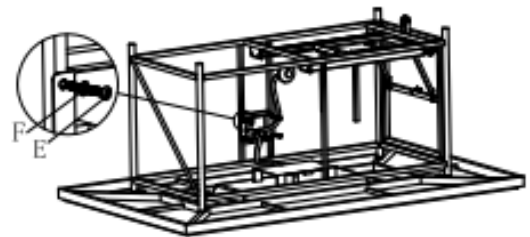

4

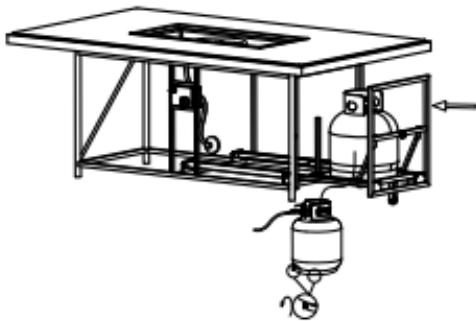

For replacement or lost spare parts please go to <http://spares.hartmanuk.co.uk/purchase>

Should you have any queries about your furniture your first point of contact should be the retailer from whom you purchased your product

PLEASE KEEP ME WITH YOUR PROOF OF PURCHASE FOR FUTURE REFERENCE



5

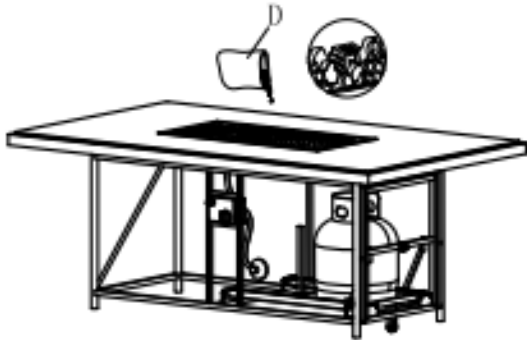

6

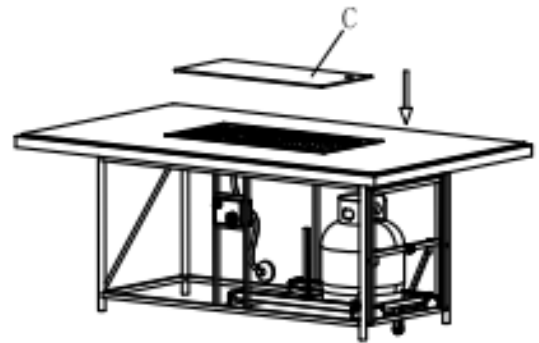

8

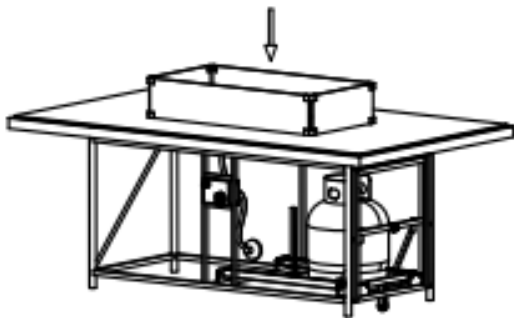

7

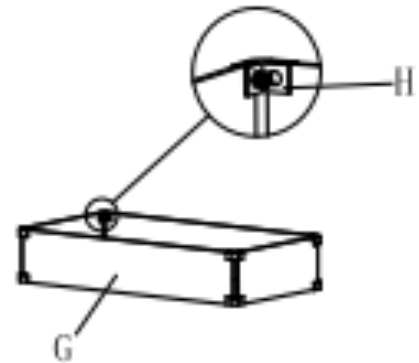

For replacement or lost spare parts please go to <http://spares.hartmanuk.co.uk/purchase>

Should you have any queries about your furniture your first point of contact should be the retailer from whom you purchased your product

PLEASE KEEP ME WITH YOUR PROOF OF PURCHASE FOR FUTURE REFERENCE

ATTENTION:







1. Please read these instructions carefully before assembly
2. Aluminium is soft metal and over tightening may strip thread or break the part
3. **DO NOT** use power tools
4. Please allow 30 minutes for assembly
5. Although assembly only requires 1 person it is advised that a second person be present to help turn the sofa over and into position when fully assembled

ASSEMBLY STEPS:

1. Position part (A) and part (B) ready for assembly
2. With 6 bolts (F) and 6 flat washers (C) **LOOSELY** attach back piece (A) with spanner (G) to seating section (B) **DO NOT TIGHTEN BOLTS AT THIS STAGE.**
3. With 2 bolts (D) and 2 flat washers (C) **LOOSELY** attach front and rear leg with spanner (G) to seating section (B) **DO NOT TIGHTEN BOLTS AT THIS STAGE.**
4. **TIGHTEN ALL BOLTS AT THIS STAGE.**
5. Tighten all bolts using the spanner (G) cover all bolts using nut cap (E)
6. Turn it over and place in desired position

For more information regarding maintenance of your furniture please visit

http://www.hartmanuk.co.uk/after_care_videos.html

Component's					Fixings				
Parts List	Parts Picture	Description	Q'ty	Part no	Parts list	Parts Picture	Description	Q'ty	Part no.
A		Backrest with LH arm	1	68118145A 68131146A	C		Big Flat Washers	8	1061162
B		Seating Section	1	68118145B 68131146B	D		M6*40 bolts	2	1006162
					E		Nut cap	8	2100038 2100039
					F		M6*45 bolts	6	1131162
					G		Spanner	1	2100041

For replacement or lost spare parts please go to <http://faq.hartmanuk.co.uk/spares/>

Should you have any queries about your furniture your first point of contact should be the retailer from whom you purchased your product

PLEASE KEEP ME WITH YOUR PROOF OF PURCHASE FOR FUTURE REFERENCE

ASSEMBLY INSTRUCTIONS

Heritage Rectangular Casual Dining Corner

(68118145 / 68131146)

1

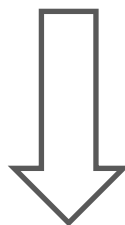
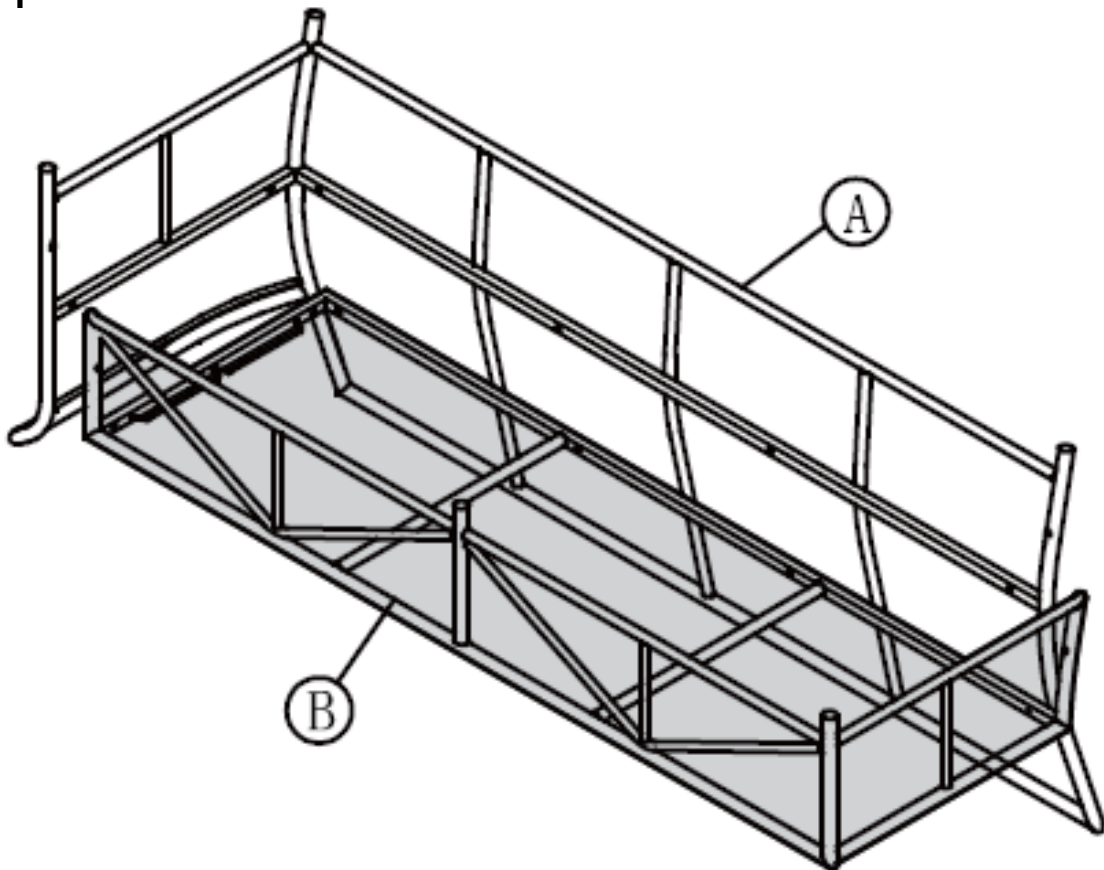

For replacement or lost spare parts please go to <http://faq.hartmanuk.co.uk/spares/>
Should you have any queries about your furniture your first point of contact should be the retailer from whom you purchased your product

PLEASE KEEP ME WITH YOUR PROOF OF PURCHASE FOR FUTURE REFERENCE

2

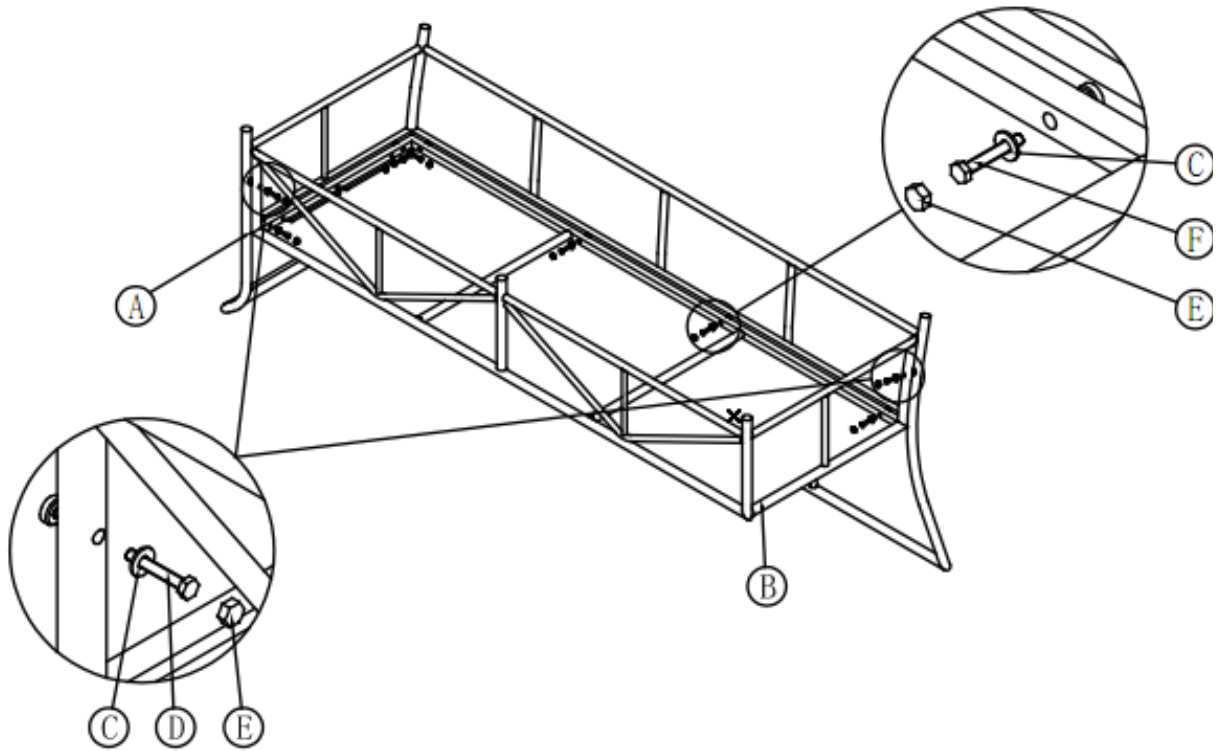

For replacement or lost spare parts please go to <http://faq.hartmanuk.co.uk/spares/>
Should you have any queries about your furniture your first point of contact should be the retailer from whom you purchased your product

PLEASE KEEP ME WITH YOUR PROOF OF PURCHASE FOR FUTURE REFERENCE

3

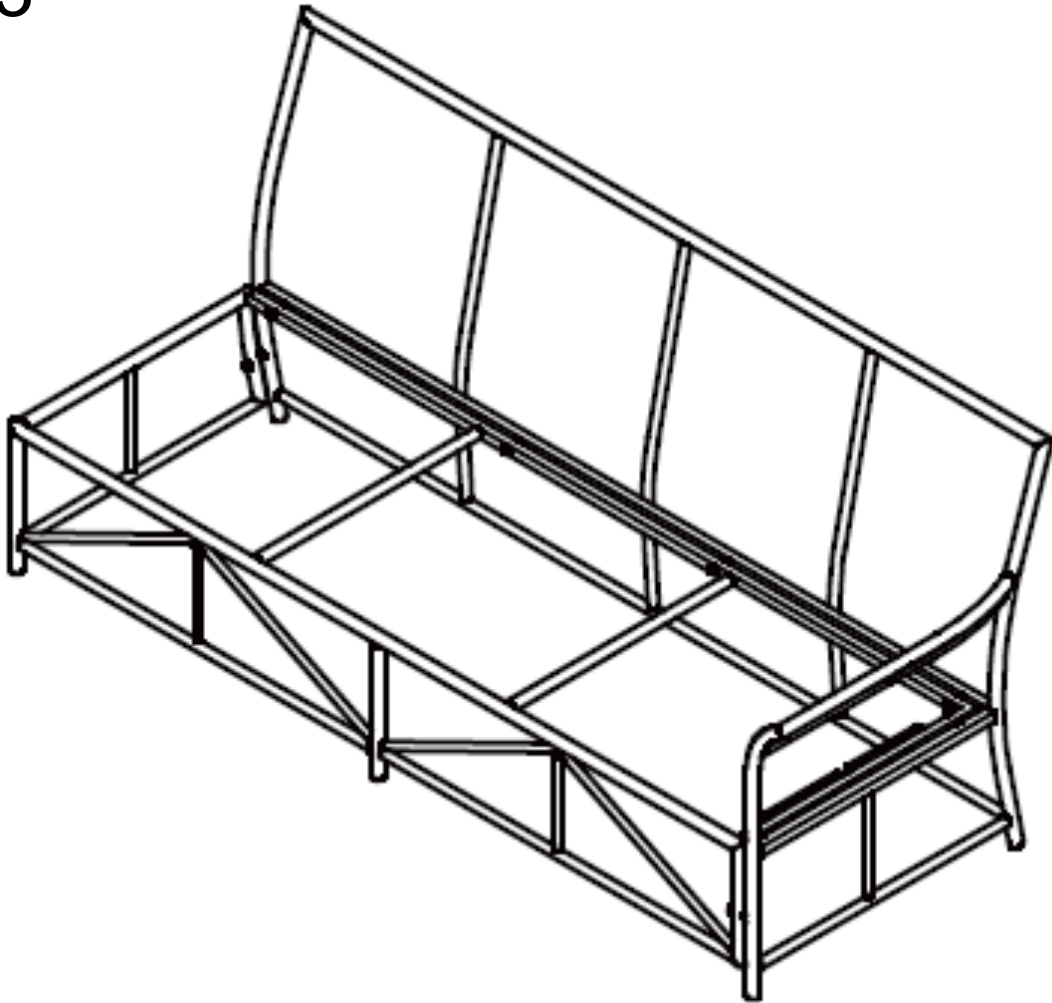

For replacement or lost spare parts please go to <http://faq.hartmanuk.co.uk/spares/>
Should you have any queries about your furniture your first point of contact should be the retailer from whom you purchased your product

PLEASE KEEP ME WITH YOUR PROOF OF PURCHASE FOR FUTURE REFERENCE

ATTENTION:



1. Please read these instructions carefully before assembly
2. Aluminium is soft metal and over tightening may strip thread or break the part
3. **DO NOT** use power tools
4. Please allow 30 minutes for assembly
5. Although assembly only requires 1 person it is advised that a second person be present to help turn the sofa over and into position when fully assembled

ASSEMBLY STEPS:

1. Position part (A1) and part (B1) ready for assembly
2. With 2 brackets (C1) position over the section that adjoin parts (A1) and (B1). Diagram 2..
3. Turn sofas over and place in desired position.
4. Put all cushions on the sofa

For more information regarding maintenance of your furniture please visit

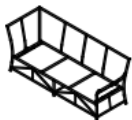
http://www.hartmanuk.co.uk/after_care_videos.html

Component's				Fixings					
Parts List	Parts Picture	Description	Q'ty	Part no	Parts list	Parts Picture	Description	Q'ty	Part no.
A1		RH Sofa	1	68118145RH 68131146RH					
B1		LH Sofa	1	68118145LH 68131146LH					
C1		Bracket	2	2002189					

For replacement or lost spare parts please go to <http://faq.hartmanuk.co.uk/spares/>

Should you have any queries about your furniture your first point of contact should be the retailer from whom you purchased your product

PLEASE KEEP ME WITH YOUR PROOF OF PURCHASE FOR FUTURE REFERENCE

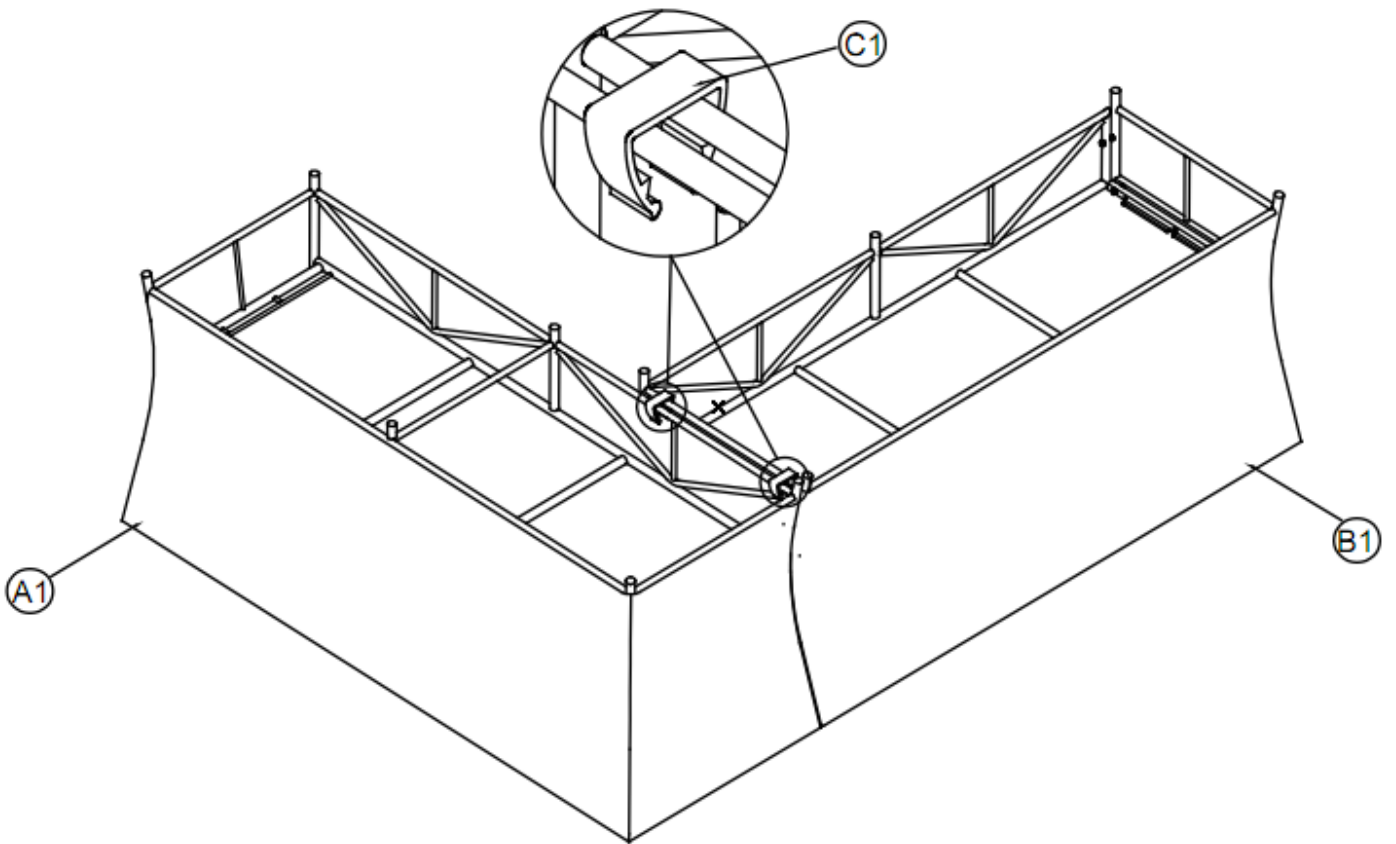

For replacement or lost spare parts please go to <http://faq.hartmanuk.co.uk/spares/>
Should you have any queries about your furniture your first point of contact should be the retailer from whom you purchased your product