

PLEASE KEEP ME WITH YOUR PROOF OF PURCHASE FOR FUTURE REFERENCE



ASSEMBLY INSTRUCTIONS

Dubai 3 Seat Lounge Sofa, Lounge Chair(x2) and 170 x50cm Casual Table

(69119012)

ATTENTION:









1. Please read these instructions carefully before assembly
2. Aluminium is soft metal and over tightening may strip thread or break the part
3. **DO NOT** use power tools
4. Please allow 30 minutes for assembly.
5. Although assembly only requires 1 person it is advised that a second person be present to help turn the table over and into position when fully assembled

LOUNGE CHAIR ASSEMBLY STEPS:

1. Turn the chair (A) upside down on a soft clean surface
2. **LOOSELY** attach Seating panel (B) to the chair (A) with 4 bolts (F), 2 bolts (G) and 6 big flat washers (H) using Allen key (I)
3. **LOOSELY** attach legs (C) to Sofa (A) with 6 bolts (G) and 6 big flat washers (H) using Allen key (I) **DO NOT TIGHTEN THE BOLTS AT THIS STAGE**
4. Tighten all bolts using Allen key (I) one by one being careful not to over tighten any as this will cause the thread to become damaged
5. Turn Sofa over and place in desired position.
6. Place all cushions (D&E) on the sofa seat

For more information regarding maintenance of your furniture please visit

http://www.hartmanuk.co.uk/after_care_videos.html

Component's					Fixings				
Parts List	Parts Picture	Description	Q'ty	Part no	Parts list	Parts Picture	Description	Q'ty	Part no.
A		chair	1	69020012A	F		M6*35 bolts	4	1111162
					G		M6*25 bolts	8	2002173
B		Seating panel	1	69020012B	H		Big Flat washers	12	1061162
C		Leg	2	69020012C	I		Allen Key	1	2002191
D		Seat cushion	1	69020012D					
E		Back cushion	1	69020012E					

For replacement or lost spare parts please go to <http://faq.hartmanuk.co.uk/spares/>

Should you have any queries about your furniture your first point of contact should be the retailer from whom you purchased your product

PLEASE KEEP ME WITH YOUR PROOF OF PURCHASE FOR FUTURE REFERENCE



ASSEMBLY INSTRUCTIONS

Lounge Chair(x2)

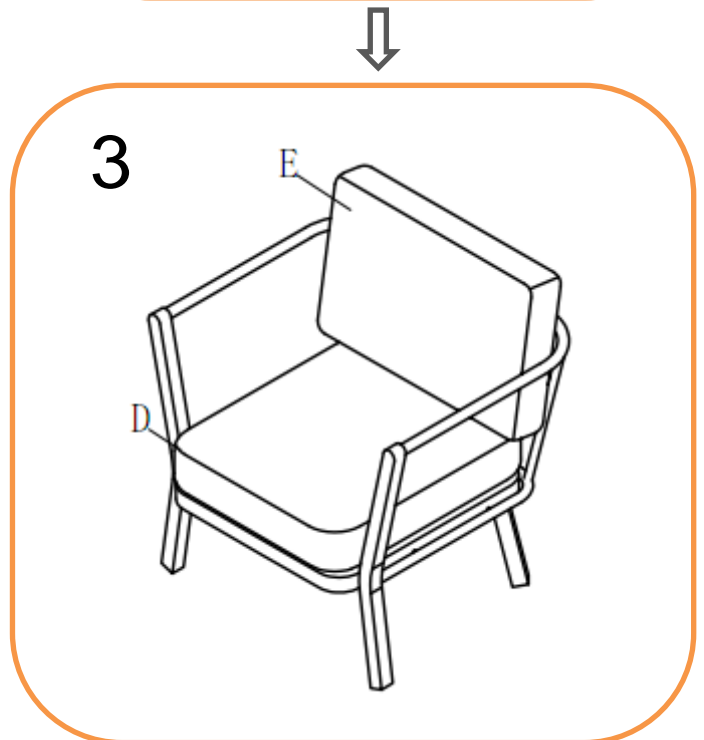
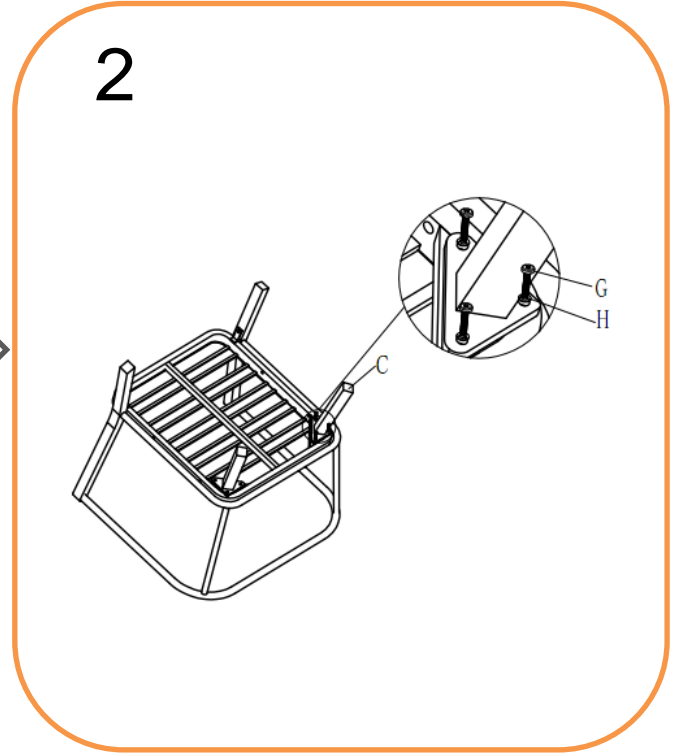
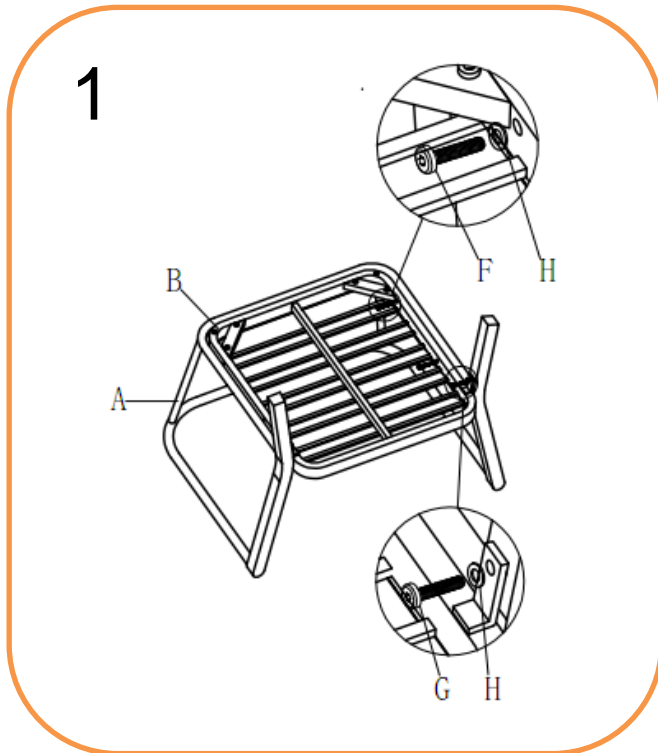

For replacement or lost spare parts please go to <http://faq.hartmanuk.co.uk/spares/>

Should you have any queries about your furniture your first point of contact should be the retailer from whom you purchased your product

PLEASE KEEP ME WITH YOUR PROOF OF PURCHASE FOR FUTURE REFERENCE

ATTENTION:









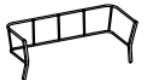

1. Please read these instructions carefully before assembly
2. Aluminium is soft metal and over tightening may strip thread or break the part
3. **DO NOT** use power tools
4. Please allow 30 minutes for assembly.
5. Although assembly only requires 1 person it is advised that a second person be present to help turn the table over and into position when fully assembled

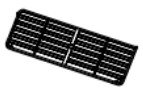
3 SEAT SOFA ASSEMBLY STEPS:

1. Turn the sofa (A) upside down on a soft clean surface
2. **LOOSELY** attach Seating panel (B) to the Sofa (A) with bolts (H), bolts (I) and big flat washers (K) using Allen key (L)
3. **LOOSELY** attach 2 legs (C) to Sofa (A) with bolts (I) and big flat washers (K) using Allen key (L) **DO NOT TIGHTEN THE BOLTS AT THIS STAGE**
4. **LOOSELY** attach middle leg (D) to seating panel (B) with bolts (I) and big flat washers (K) using Allen key (L)
5. **LOOSELY** attach rear middle leg (E) to seating panel (B) with bolts (J) and big flat washers (K) using Allen key (L)
6. Tighten all bolts using Allen key (L) one by one being careful not to over tighten any as this will cause the thread to become damaged
7. Turn Sofa over and place in desired position.
8. Place all cushions(F&G) on the sofa seat

For more information regarding maintenance of your furniture please visit

http://www.hartmanuk.co.uk/after_care_videos.html

Component's					Fixings				
Parts List	Parts Picture	Description	Q'ty	Part no	Parts list	Parts Picture	Description	Q'ty	Part no.
A		Sofa	1	69119012A	F		Seat cushion	1	69119012F
					G		Back cushion	3	69119012G
B		Seating panel	1	69119012B	H		M6*35 bolts	8	1111162
C		Rear Leg	2	69119012C	I		M6*25 bolts	12	2002173
D		Middle leg	1	69119012D	J		M6*15 bolts	2	2100095
E		Rear middle leg	1	69119012E	K		Big Flat washers	22	1061162
					L		Allen Key	1	2002191

For replacement or lost spare parts please go to <http://faq.hartmanuk.co.uk/spares/>

Should you have any queries about your furniture your first point of contact should be the retailer from whom you purchased your product

PLEASE KEEP ME WITH YOUR PROOF OF PURCHASE FOR FUTURE REFERENCE

ASSEMBLY INSTRUCTIONS

Dubai 3 Seat Sofa

1

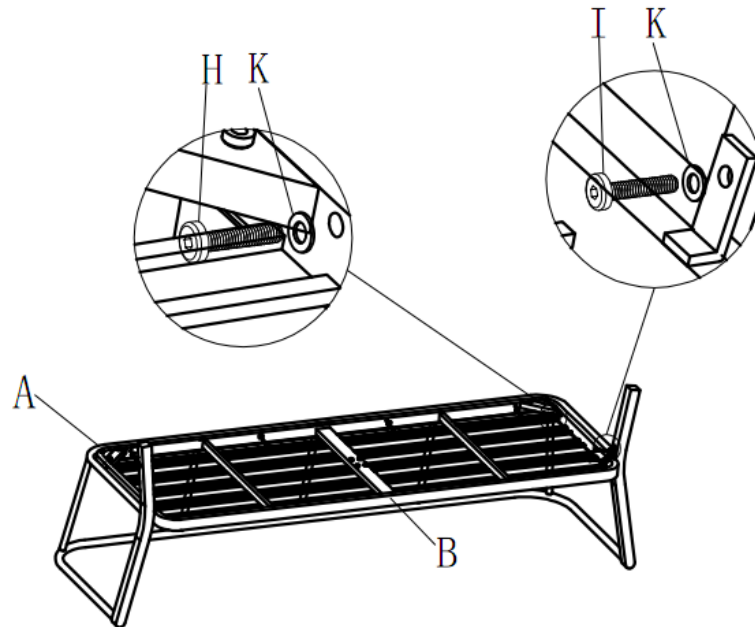

2

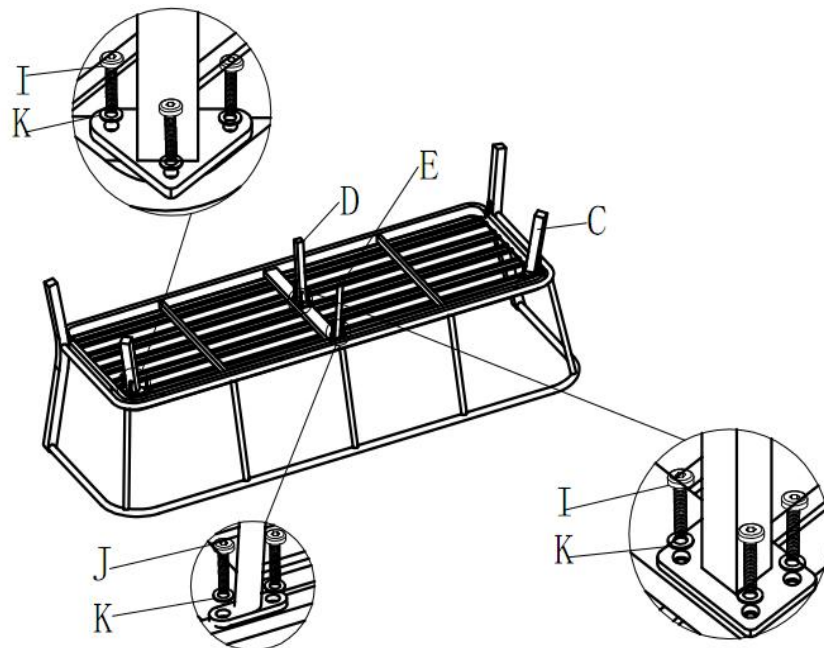

For replacement or lost spare parts please go to <http://faq.artmanuk.co.uk/spares/>
Should you have any queries about your furniture your first point of contact should be the retailer from whom you purchased your product

PLEASE KEEP ME WITH YOUR PROOF OF PURCHASE FOR FUTURE REFERENCE

3

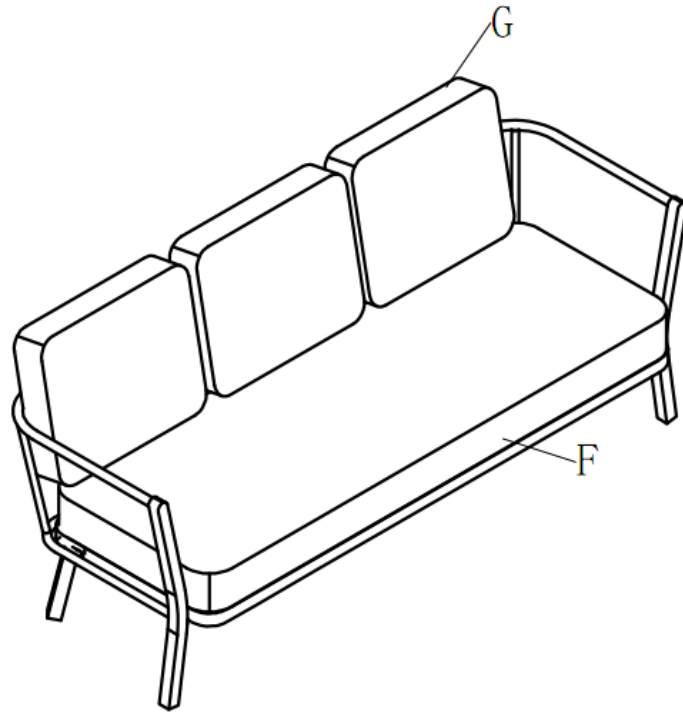

For replacement or lost spare parts please go to <http://faq.hartmanuk.co.uk/spares/>
Should you have any queries about your furniture your first point of contact should be the retailer from whom you purchased your product

PLEASE KEEP ME WITH YOUR PROOF OF PURCHASE FOR FUTURE REFERENCE

ATTENTION:







1. Please read these instructions carefully before assembly
2. Aluminium is soft metal and over tightening may strip thread or break the part
6. **DO NOT** use power tools
3. Please allow 30 minutes for assembly.
4. Although assembly only requires 1 person it is advised that a second person be present to help turn the table over and into position when fully assembled.

170 x 50cm Casual Table ASSEMBLY STEPS:

1. Turn the table top (A) upside down on a soft clean surface
2. **LOOSELY** attach leg (B) to table top (A) with bolts (E) and big flat washers (F) using Allen key (G) **DO NOT TIGHTEN THE BOLTS AT THIS STAGE**
3. **LOOSELY** attach the ring (C) to legs (B) with bolts (E) and big flat washers (F) using Allen key (G) **DO NOT TIGHTEN THE BOLTS AT THIS STAGE**
4. Tighten all bolts using Allen key (G) one by one being careful not to over tighten any as this will cause the thread to become damaged
5. Turn over and place in desired position.
6. Place glass (D) back on table and gently press down on suckers to ensure glass is secure

For more information regarding maintenance of your furniture please visit

http://www.hartmanuk.co.uk/after_care_videos.html

Component's				Fixings					
Parts List	Parts Picture	Description	Q'ty	Part no	Parts list	Parts Picture	Description	Q'ty	Part no.
A		Table top	1		E		M6*25 bolts	12	
					F		Big Flat washers	12	
B		Leg	4		G		Allen Key	1	
C		Ring	1						
D		Glass	1						

For replacement or lost spare parts please go to <http://faq.hartmanuk.co.uk/spares/>

Should you have any queries about your furniture your first point of contact should be the retailer from whom you purchased your product

PLEASE KEEP ME WITH YOUR PROOF OF PURCHASE FOR FUTURE REFERENCE
ASSEMBLY INSTRUCTIONS

170 x50cm Casual Table

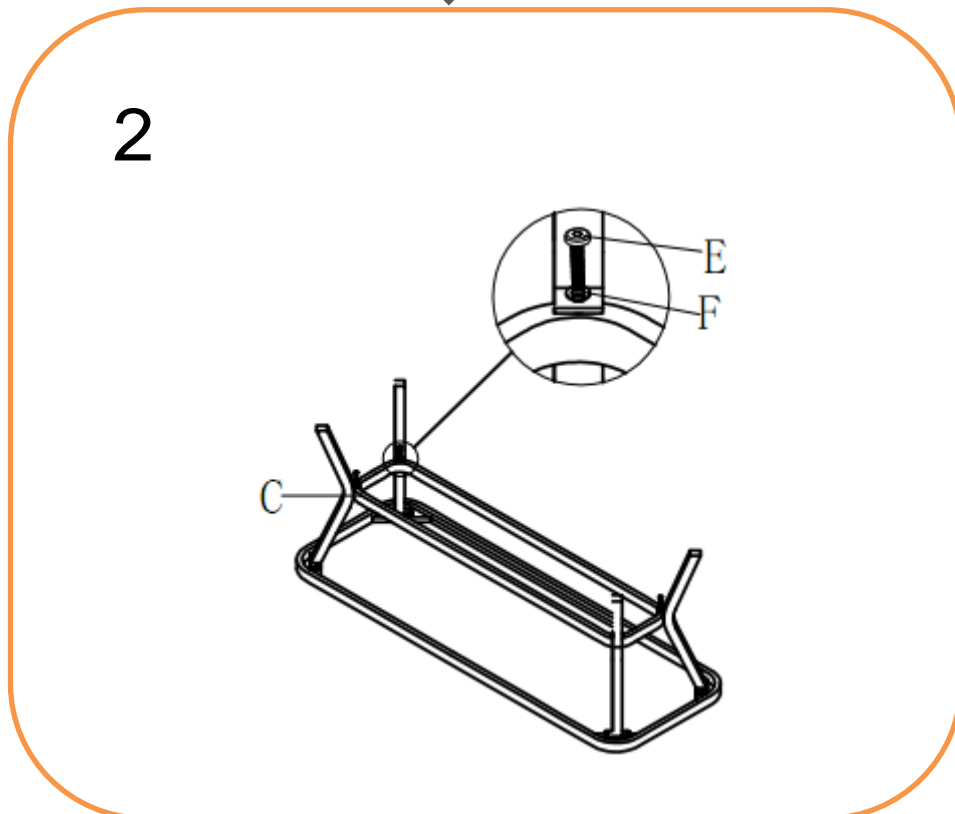
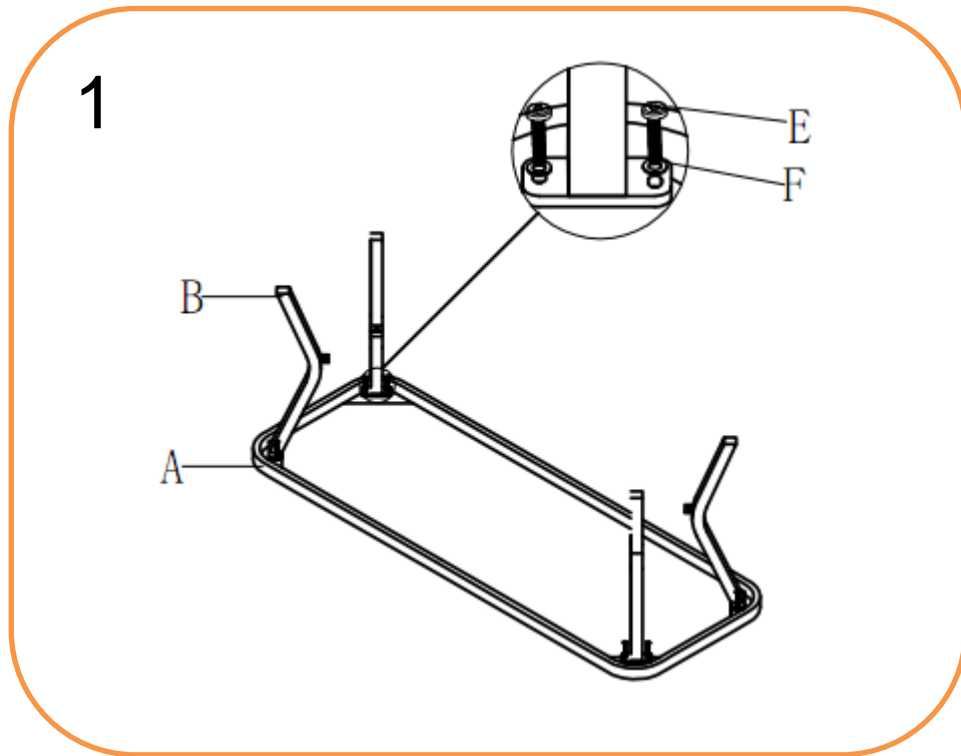

For replacement or lost spare parts please go to <http://faq.hartmanuk.co.uk/spares/>
Should you have any queries about your furniture your first point of contact should be the retailer from whom you purchased your product

PLEASE KEEP ME WITH YOUR PROOF OF PURCHASE FOR FUTURE REFERENCE



3

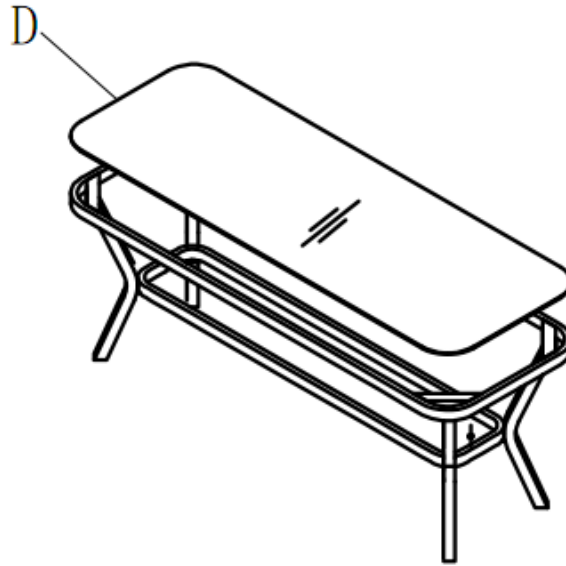

4

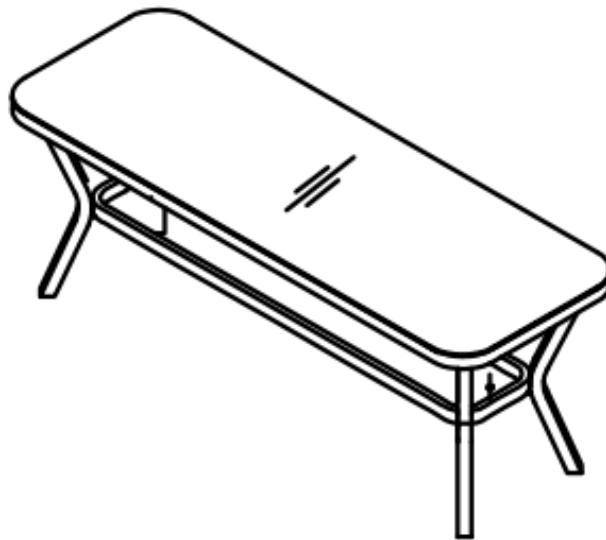

For replacement or lost spare parts please go to <http://faq.hartmanuk.co.uk/spares/>
Should you have any queries about your furniture your first point of contact should be the retailer from whom you purchased your product

PLEASE KEEP ME WITH YOUR PROOF OF PURCHASE FOR FUTURE REFERENCE



ASSEMBLY INSTRUCTIONS

Dubai

170x45cm Extra Long Stool (3 Seat Bench)

(69120012)

ATTENTION:







1. Please read these instructions carefully before assembly
2. Aluminium is soft metal and over tightening may strip thread or break the part
3. **DO NOT** use power tools
4. Please allow 30 minutes for assembly.
5. Although assembly only requires 1 person it is advised that a second person be present to help turn the table over and into position when fully assembled

ASSEMBLY STEPS:

1. Turn the seating panel (A) upside down on a soft clean surface
2. **LOOSELY** attach legs (B) to the seating panel (A) with bolts(E), and big flat washers(F) using Allen key(G)
3. **LOOSELY** attach ring (C) to assembled legs with bolts (E) and big flat washers (F) using Allen key (G) **DO NOT TIGHTEN THE BOLTS AT THIS STAGE**
4. Tighten all bolts using Allen key (G) one by one being careful not to over tighten any as this will cause the thread to become damaged
5. Turn Stool over and place in desired position.
6. Place seat cushion(D) on the stool

For more information regarding maintenance of your furniture please visit

http://www.hartmanuk.co.uk/after_care_videos.html

Component's					Fixings				
Parts List	Parts Picture	Description	Q'ty	Part no	Parts list	Parts Picture	Description	Q'ty	Part no.
A		Seating panel	1	69120012A	E		M6*25 bolts	12	1231162
					F		Big Flat washers	12	1061162
B		Leg	4	69120012B	G		Allen key	1	2002191
C		ring	1	69120012C					
D		Seat cushion	1	69120012D					

For replacement or lost spare parts please go to <http://faq.hartmanuk.co.uk/spares/>

Should you have any queries about your furniture your first point of contact should be the retailer from whom you purchased your product

PLEASE KEEP ME WITH YOUR PROOF OF PURCHASE FOR FUTURE REFERENCE



ASSEMBLY INSTRUCTIONS

170x45cm Extra Long Stool (3 Seat Bench)

(69120012)

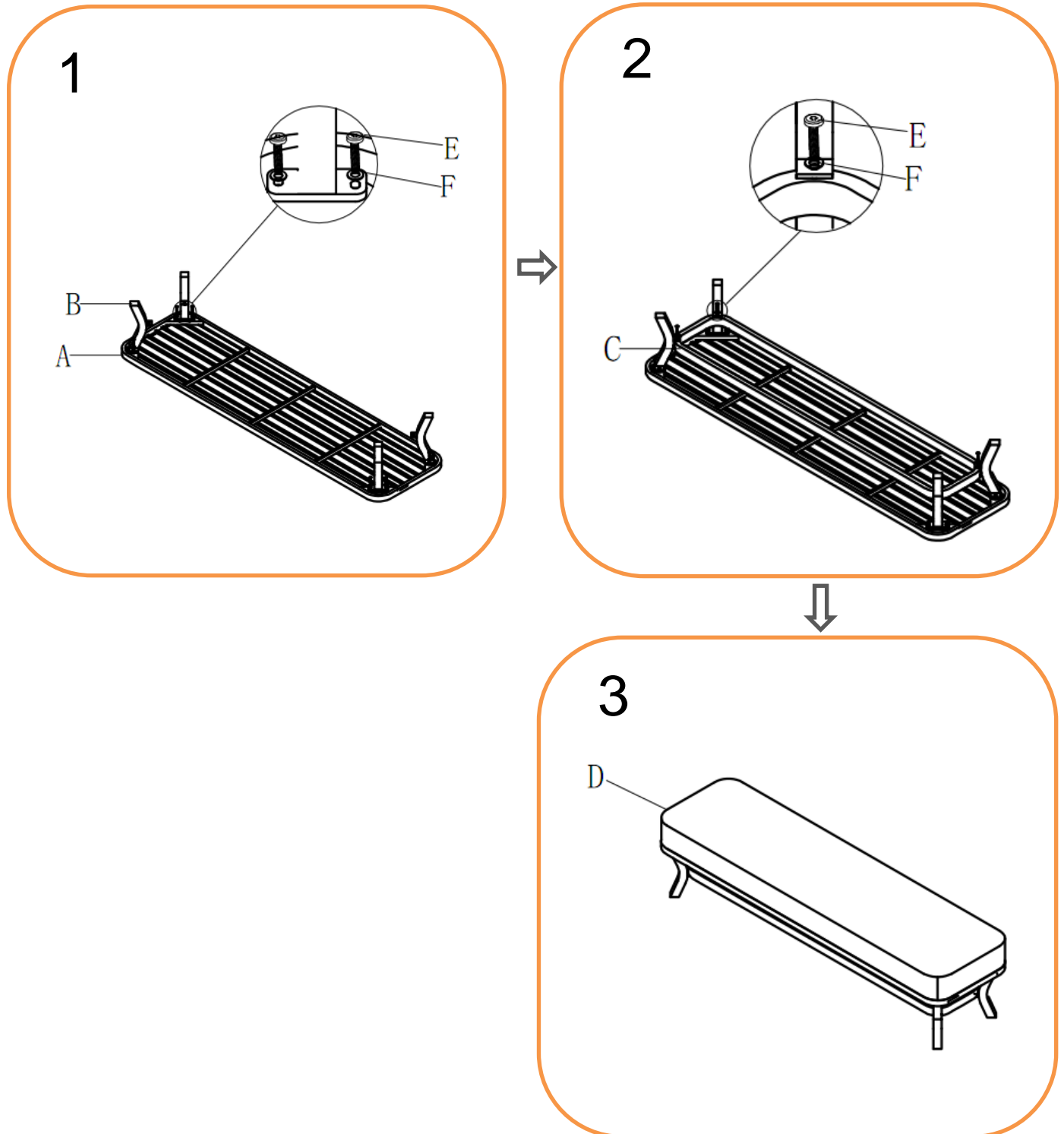

For replacement or lost spare parts please go to <http://faq.hartmanuk.co.uk/spares/>
Should you have any queries about your furniture your first point of contact should be the retailer from whom you purchased your product